



## CARACTÉRISTIQUES TECHNIQUES



Moteur  
YAMAHA PW-X3 - 250 W - 85 NM



Batterie  
MATRA - 630 WH



Temps de charge / Autonomie\*  
100 % : 7H00 / 70>150 KM



Display  
YAMAHA DÉPORTÉ TYPE X, LED



Assistance  
5 MODES D'ASSISTANCE DONT MODE EXPW  
+ MODE AUTOMATIQUE + MODE PIÉTON



Cadre  
ALUMINIUM



Fourche  
ROCKSHOX REVELATION BOOST 120 MM



Transmission / vitesses  
SHIMANO DEORE / 12 VITESSES



Freins  
À DISQUE HYDRAULIQUES SHIMANO



Potence  
FIXE ALUMINIUM 50 MM



Guidon  
CINTRE : DROIT 740 MM  
POIGNÉES : BI-MATIÈRE



Jantes  
27,5" - MACH 1 ALUMINIUM - 32 RAYONS



Pneus  
MAXXIS REKON 27.5 X 2.6



Selle  
SELLE ROYAL VIVO



Tige de selle  
RIGIDE ALUMINIUM



Éclairage  
A PILE AVANT ET ARRIÈRE



Tailles  
S : 43 CM - 27,5" / M : 45 CM - 27,5" / L : 47 CM - 27,5"



Garantie  
CADRE 10 ANS, MOTEUR ET BATTERIE 2 ANS

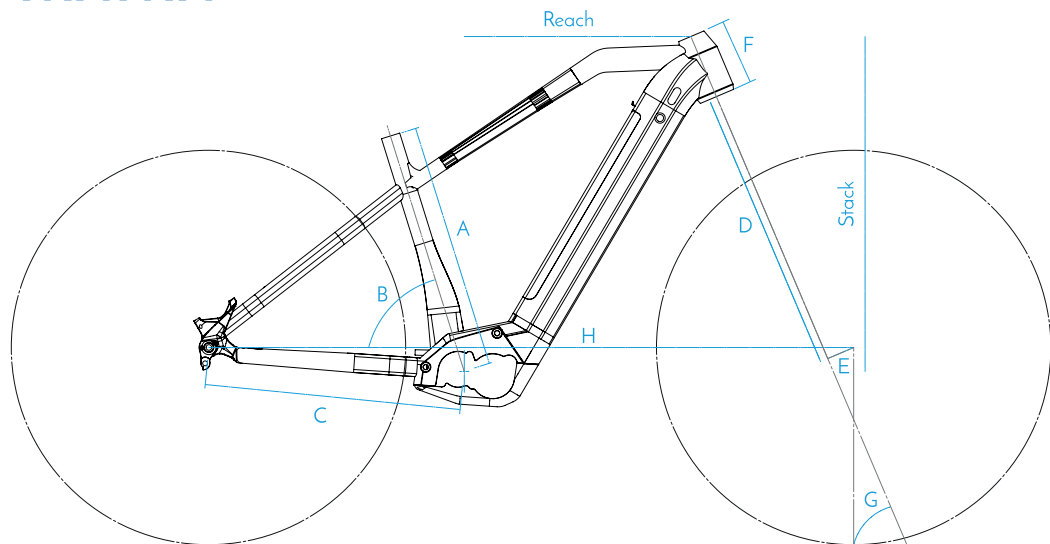

Taille	S	M	L
Taille cycliste	1m60 - 1m73	1m72 - 1m85	1m84 - 1m95
Reach : Distance horizontale pédalier > guidon	410mm	430mm	450mm
Stack : Élévation pédalier > guidon	610mm	616mm	620mm
Diamètre de roue	27.5"	27.5"	27.5"
Suspension avant	120mm		
A - Longueur du tube de selle	430mm	450mm	470mm
B - Angle du tube de selle	74°		
C - Longueur des bases	460mm		
D - Longueur de fourche	516.5mm		
E - Déport de la fourche	46mm		
F - Longueur douille de direction	115mm	120mm	125mm
G - Angle de chasse	67°		
H - Empattement	1160mm	1180mm	1200mm