



I-FORCE PLAY D 9

Prix public conseillé :  
3 599 € TTC



ROUGE  
VELOURS

MOTEUR CENTRAL BOSCH  
PERFORMANCE LINE 65 NM

500 WH  
Autonomie max.  
115 KM

ePowered by  
BOSCH

## CARACTÉRISTIQUES TECHNIQUES



Moteur  
CENTRAL BOSCH PERFORMANCE LINE - 65 NM



Batterie  
BOSCH POWERTUBE 36 V / 13,4 AH - 500 WH



Temps de charge / Autonomie\*  
100 % : 5H30 / 55>115 KM



Display  
BOSCH PURION



Assistance  
5 MODES D'ASSISTANCE (DONT MODE SPÉCIAL VTT)  
+ MODE PIÉTON



Cadre  
ALUMINIUM, BATTERIE INTÉGRÉE



Fourche  
SUSPENDUE SR SUNTOUR XCR 32 120 MM



Dérailleur / vitesses  
SHIMANO ACERA / 9 VITESSES



Freins  
À DISQUE HYDRAULIQUES TEKTRO  
180 MM AV. ET 160 MM AR.



Potence  
FIXE 90 MM



Guidon  
CINTRE : 740 X 31,8 X 19,9  
POIGNÉES : VELO SPORT TYPE LOCK ON 130



Jantes  
27,5" - MACH 1 - 32 RAYONS



Pneus  
MICHELIN WILD GRIP R 27,5 X 2,25



Selle  
SELLE ROYAL SHADOW



Tige de selle  
JD COMPONENTS 31,6 X 350 MM



Éclairage  
AV : SPANNINGA ILLICO / AR : SPANNINGA PRESTO



Tailles  
S : 43 CM - 27,5" / M : 45 CM - 27,5" / L : 47 CM - 27,5"



Garantie  
CADRE 10 ANS, MOTEUR ET BATTERIE 2 ANS

\* Les autonomies sont indiquées à titre indicatif. Elles sont mesurées selon un protocole de tests défini par Easybike Group ou communiquées par le fabricant de batteries. Les facteurs de perte d'autonomie principaux sont : vent contraire, dénivelés positifs, température inférieure à 15°C, pneus sous-gonflés, poids de l'utilisateur supérieur au poids nominal défini pour nos tests (70 kg), mauvais réglages du vélo, mauvaise utilisation des vitesses.

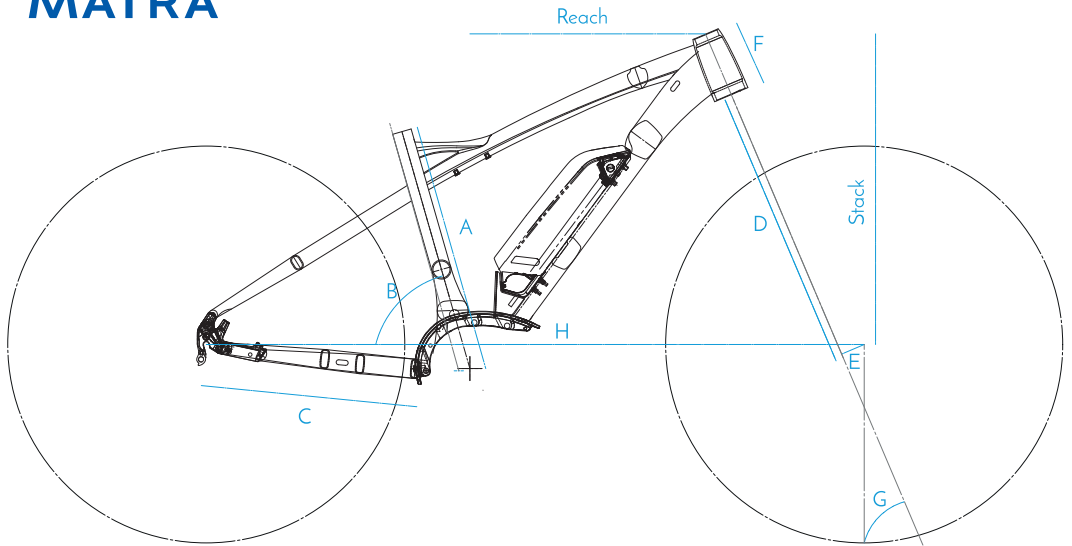

Taille	S	M	L
Reach : Distance horizontale pédalier > guidon	410mm	430mm	450mm
Stack : Élévation pédalier > guidon	606mm	611mm	616mm
Diamètre de roue	27.5"	27.5"	27.5"
Suspension avant	120mm		
Suspension arrière	-		
A - Longueur du tube de selle	430mm	450mm	470mm
B - Angle du tube de selle	74°		
C - Longueur des bases	488mm		
D - Longueur de fourche	512mm		
E - Déport de la fourche	46mm		
F - Longueur douille de direction	115mm	120mm	125mm
G - Angle de chasse	67°		
H - Empattement	1179mm	1200mm	1222mm