



















● BLANC ● NOIR

 MOTEUR CENTRAL YAMAHA
PW-S2 75 NM

 500 WH
Autonomie max.
110 KM



CARACTÉRISTIQUES TECHNIQUES

- | | |
|--|---|
|  Moteur
YAMAHA PW-S2 - 250 W - 75 NM |  Potence
AHEADSET |
|  Batterie
MATRA - 500 WH |  Guidon
CINTRE : 420 MM
GUIDOLINE : FIZIK |
|  Temps de charge / Autonomie*
100 % : 5H30 / 50>110 KM |  Jantes
ALUMINIUM 700C |
|  Display
YAMAHA DÉPORTÉ TYPE A, LED |  Pneus
MAXXIS RE-FUSE 700 X 32C |
|  Assistance
4 MODES D'ASSISTANCE + MODE AUTOMATIQUE + MODE PIÉTON |  Selle
SELLE ROYAL VIVO |
|  Cadre
ALUMINIUM |  Tige de selle
RIGIDE ALUMINIUM |
|  Fourche
RIGIDE CARBONE |  Tailles
S : 42,5 CM - 700C / M : 45 CM - 700C / L : 46 CM - 700C |
|  Transmission / vitesses
SRAM FORCE 11X28 / 11 VITESSES |  Garantie
CADRE 10 ANS, MOTEUR ET BATTERIE 2 ANS |
|  Freins
À DISQUE HYDRAULIQUES SRAM FORCE 160 MM AV. ET AR. | |

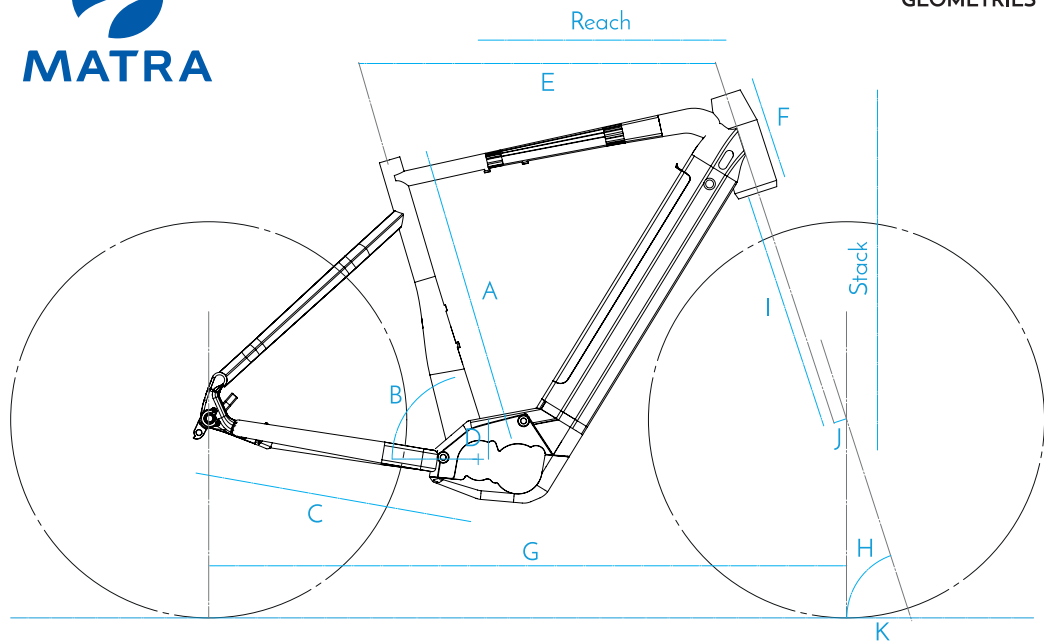

Taille	S	M	L
Taille cycliste	1m60 - 1m73	1m72 - 1m85	1m84 - 1m95
Reach : Distance horizontale pédalier > guidon	400mm	407mm	417mm
Stack : Élévation pédalier > guidon	592mm	600mm	620mm
A - Longueur du tube de selle	425mm	450mm	460mm
B - Angle du tube de selle	73.5°		
C - Longueur des bases	440mm		
D - Distance pédalier > axes des roues	73mm		
E - Longueur tube supérieur	575mm	585mm	600mm
F - Longueur douille de direction	140mm	170mm	180mm
G - Empattement	1050mm	1052mm	1070mm
H - Angle de chasse	72°		
I - Longueur de fourche	400mm		
J - Déport de la fourche	45mm		
K - Chasse	66.7mm	66.7mm	63.5mm