



I-STEP CROSS D11 CX

Prix public conseillé
4 999 € TTC



OR

 **MOTEUR CENTRAL BOSCH G4 PERFORMANCE LINE CX 85 NM**

 **500 WH**
Autonomie max.
115 KM

ePowered by
 **BOSCH**

CARACTÉRISTIQUES TECHNIQUES



Moteur
CENTRAL BOSCH G4 PERFORMANCE LINE CX - 85 NM



Batterie
BOSCH POWERTUBE 36 V / 13,4 AH - 500 WH



Temps de charge / Autonomie*
100 % : 5H30 / 55>115 KM



Display
BOSCH PURION



Assistance
**5 MODES D'ASSISTANCE (DONT MODE SPÉCIAL VTT)
+ MODE PIÉTON**



Cadre
ALUMINIUM



Fourche
SUSPENDUE ROCKSHOX RECON BOOST 140 MM



Amortisseur
ROCKSHOX MONARCH 130 MM



Dérailleur / vitesses
SHIMANO DEORE / 11 VITESSES



Freins
**À DISQUE HYDRAULIQUES SHIMANO ACERA (ÉTRIERS) /
DEORE (DISQUES) 200 MM AV. ET 180 MM AR.**



Potence
FIXE 50 MM



Guidon
POIGNÉES : VTC ERGONOMIQUES



Jantes
27,5"



Pneus
SCHWALBE NOBBY NIC CLASSIC SKIN 27,5 X 2,25



Selle
VTC CONFORT



Tige de selle
SUSPENDUE



Éclairage
AVANT ET ARRIÈRE



Accessoires
BÉQUILLE / PORTE-BAGAGE / GARDE-BOUES



Tailles
S : 42,5 CM - 27,5" / M : 45 CM - 27,5" / L : 48 CM - 27,5"



Garantie
CADRE 10 ANS, MOTEUR ET BATTERIE 2 ANS

* Les autonomies sont indiquées à titre indicatif. Elles sont mesurées selon un protocole de tests défini par Easybike Group ou communiquées par le fabricant de batteries. Les facteurs de perte d'autonomie principaux sont : vent contraire, dénivelés positifs, température inférieure à 15°C, pneus sous-gonflés, poids de l'utilisateur supérieur au poids nominal défini pour nos tests (70 kg), mauvais réglages du vélo, mauvaise utilisation des vitesses.

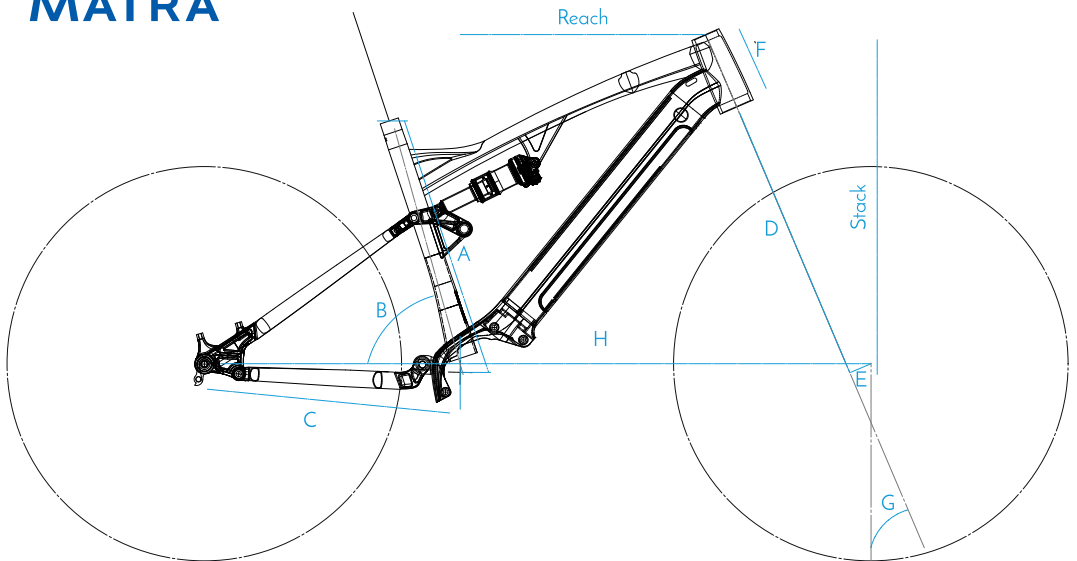

Taille	S	M	L
Reach : Distance horizontale pédalier > guidon	425mm	435mm	450mm
Stack : Élévation pédalier > guidon	599mm	611mm	620mm
Diamètre de roue	27.5"	27.5"	27.5"
Suspension avant	140mm		
Suspension arrière	130mm		
A - Longueur du tube de selle	425mm	450mm	480mm
B - Angle du tube de selle	74.5°		
C - Longueur des bases	470mm		
D - Longueur de fourche	532mm		
E - Déport de la fourche	46mm		
F - Longueur douille de direction	125mm	135mm	145mm
G - Angle de chasse	66.5°		
H - Empattement	1200mm	1214mm	1233mm